



Northbrook, Illinois (847) 272-8800  
Melville, New York (631) 271-6200  
Santa Clara, California (408) 985-2400  
Research Triangle Park,  
North Carolina (919) 549-1400  
Camas, Washington (360) 817-5500

STEEL CONSTRUCTION SYSTEMS INC  
UL COORDINATOR  
11250 ASTRONAUT BLVD  
ORLANDO FL 32837

Your most recent Certification is shown below. Please review the text and contact the Conformity Assessment Services staff member who handled your project if revisions are required. For instructions on placing an order for this information in a 3 x 5-inch format, you may refer to the enclosed order form for UL Card Service.

### Design No. P540 File #R20982

Restrained Assembly Rating - 1 Hr  
Unrestrained Assembly Rating - 1 Hr

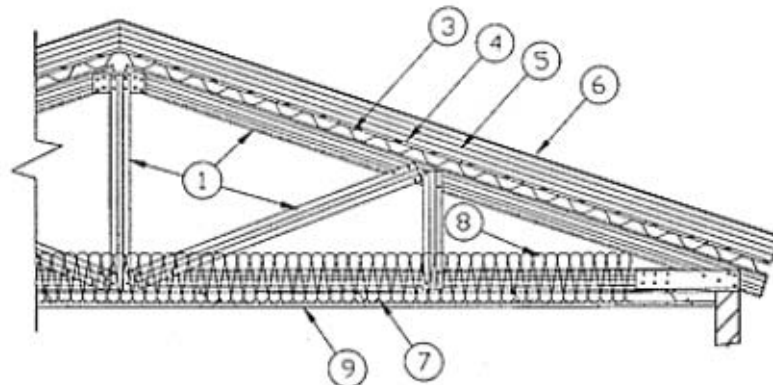
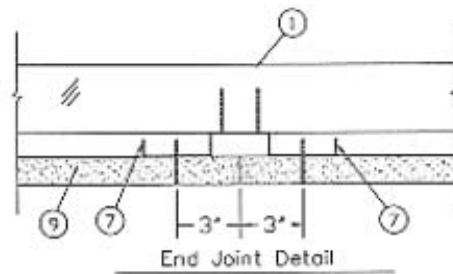
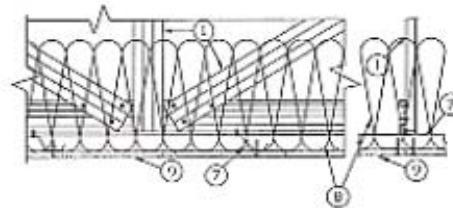

- 1. Structural Steel Members\*** - Pre-fabricated light gauge steel truss system consisting of cold-formed, galvanized steel chord and web sections. Trusses fabricated in various sizes, depths, and from various steel thickness. Trusses spaced a max of 48 in. OC.  
**AEGIS METAL FRAMING LLC** - Ultra-Span, Pre-fabricated Light Gauge Steel Truss System.  
**ALLIED STUDCO** - Amkey System, Pre-fabricated Light Gauge Steel Truss System.  
**DALE/INCOR** - Versa Truss, Pre-fabricated Light Gauge Steel Truss System  
**HEXAPORT INTERNATIONAL LTD** - Strong stud, Pre-fabricated Light Gauge Steel Truss System

Steel Construction Systems □  
11250 Astronaut Blvd. □  
Orlando, FL 32837 □  
Telephone (800) 548-8499 □  
Fax (407) 438-1667 □  
□

ITEC STEEL INC - Type Gus Truss System  
**STEEL CONSTRUCTION SYSTEMS INC**  
TRUSSTEEL, DIV OF  
ALPINE ENGINEERED PRODUCTS INC - TrusSteel

2. **Bridging** - (Not Shown) - Location of lateral bracing for truss chord and web sections to be specified on truss engineering.
3. **Steel Floor and Form Units** - (Classified or Unclassified) - Corrugated or fluted steel form units, min 22 MSG painted or galv steel, welded or mechanically fastened max 12 in. OC to truss-top chords.
- 3A. **Steel Floor and Form Units\*** - As an alternate to Item 3 - min 25 MSG, 15/16 in. deep, painted or galv units welded or mechanically fastened max 12 in. OC to the top chord of trusses. When used, max hourly rating is reduced to 1 hr.  
**LOADMASTER SYSTEMS INC** - Types HD, ED or PS.
4. **Gypsum Board** - (Classified or Unclassified) - (Not Shown) - Gypsum sheathing, min 1/2 in. thick, applied perpendicular to steel roof deck. End joints to occur over crests of steel roof deck. Sheathing loosely laid, adhered or mechanically attached to steel roof deck. See Gypsum Board (CKNX) category for names of Classified companies.
5. **Roof Insulation - Foamed Plastic\*** - Any polyisocyanurate foamed plastic insulation boards bearing the UL Classification Marking. No min. thickness and no limit on max overall thickness. Boards installed over the gypsum sheathing (Item 4), with the end-joints staggered in adjacent rows. Boards loosely laid, adhered or mechanically fastened to gypsum sheathing, and to steel roof deck (Item 3). See Foamed Plastic (CCVW) Category in the Fire Resistance Directory.
- 5A. **Roof Insulation - Foamed Plastic\*** - (Not Shown) - As an alternate to Item 5 - Any polystyrene foamed plastic insulation boards bearing the UL Classification Marking. No min thickness and no limit on max overall thickness. Boards installed over the gypsum sheathing (Item 4), with the end-joints staggered in adjacent rows. Boards loosely laid, adhered or mechanically fastened to gypsum sheathing, and to steel roof deck (Item 3). See Foamed Plastic (BRYX) category in the Building Materials Directory or Foamed Plastic (CCVW) category in the Fire Resistance Directory.
- 5B. **Roof Insulation - Mineral and Fiber Boards\*** - (Not Shown) - As an alternate to Item 5 - Mineral wool, glass fiber or perlite insulation boards, 24 by 48 in. min size. No min thickness and no limit on max overall thickness. Boards installed over the gypsum sheathing (Item 4), with the end-joints staggered in adjacent rows. Boards loosely laid, adhered or mechanically fastened to gypsum sheathing, and to steel roof deck (Item 3).  
See Mineral and Fiber Boards (BQXR) Category in the Building Materials Directory or Mineral and Fiber Boards (CERZ) Category in the Fire Resistance Directory.
- 5C. **Roof Insulation - Building Units\*** - (Not Shown) - As an alternate to Item 5 - Any polyisocyanurate foamed plastic insulation faced on the top surface with oriented strand board or faced on the underside or both sides with wood fiber board, bearing the UL Classification Marking for Fire Resistance. No min thickness of the polyisocyanurate foamed plastic core and no limit on max overall thickness.  
Boards installed over the gypsum sheathing (Item 4A), with the end-joints staggered in adjacent rows. Boards loosely laid, adhered or mechanically fastened to gypsum sheathing and to steel roof deck (Item 3). See Building Units (BZXX) category in the Fire Resistance Directory.
6. **Roof Covering\*** - Consisting of hot-mopped or cold-application materials compatible with insulation(s) described herein which provide Class A, B or C coverings. See Roofing Materials and Systems Directory-Roof Covering Materials (TEVT).
- 6A. **Roofing Membrane\*** - (Not Shown) - In lieu of Item 6, single-ply membrane that is either ballasted, adhered or mechanically attached to the insulation(s) described herein as permitted under the respective company's Classification. See Fire Resistance Directory-Roofing Membranes (CHCI) Category.
- 6B. **Metal Roof Deck Panels\*** - In Lieu of or in addition to Items 6 and 6A, the roof covering may consist of mechanically fastened galv or painted steel roof deck panels. Panels may be installed above a steel purlin assembly per metal roof deck manufacturer's specifications. Steel purlin assembly to be installed transverse to steel roof trusses (Item 1). A line of sealant or tape may be used at panel side and end laps. See Metal Roof Deck Panels Category in the Roofing Materials and Systems Directory (TJPV) or Fire Resistance Directory (CETW) for names of manufacturers.
- 6C. **Roof Covering\*** - In Lieu of Item 6 - Any UL Class A, B or C Prepared Roof Covering (TFWZ) acceptable for use over plywood sheathing or nonveneer APA Rated Series Sheathing. Sheathing mechanically fastened through roof insulation to top chord of steel trusses with fasteners spaced a max of 12 in. OC. As an alternate to the plywood sheathing or nonveneer APA Rated Series Sheathing, the Prepared Roof Covering (TFWZ) may be applied directly to the Building Units\* (Item 5C) if the building units also carry the UL Classification Marking for Prepared Roofing Accessories (TG DY).
7. **Furring Channels** - Resilient channels formed of 25 MSG galv steel, installed perpendicular to the trusses (Item 1), spaced a max of 12 in. OC. when batts and blankets (item 8) or loose fill material (item 8A) are used and a max of 16 in OC when they are not. Channels oriented opposite at wallboard butt-joints. Channel splices overlapped 4 in. beneath steel trusses. Channels secured to each truss with Type S-12 by 1/2 in. long screws.
- 7A. **Furring Channels** - (Not Shown) - As an alternate to Item 7 - Hat channels min 20 MSG galv steel, min 2-5/8 in. wide by min 7/8 in. deep, installed perpendicular to the trusses (Item 1) spaced a max of 12 in. OC when batts and blankets (item 8) or loose fill material (item 8A) are used and a max of 16 in. OC when they are not. Two courses of channel positioned 6 in. OC, 3 in. from each end of wallboard. Channel splices overlapped 6 in. beneath steel trusses. Channels secured to each truss with No. 18 SWG steel wire double strand saddle ties. Channels tied together with double strand of No. 18 SWG steel wire at each end overlap.
- 7B. **Furring Channels** - As an alternate to Items 7 and 7A, resilient channels, double legged formed of 25 MSG galv steel, 2-7/8 in. wide by 1/2 in. deep, installed perpendicular to steel trusses (Item 1), spaced a max of 12 in. OC when batts and blankets (item 8) or loose fill material (item 8A) are used and a max of 16 in. OC when they are not. Two courses of resilient channel positioned 6 in. OC at wallboard butt-joints (3 in. from each end of wallboard). Channel splices overlapped 4 in. beneath steel trusses. Channels secured to each truss with Type S12 by 1/2 in. long screws or with No. 18 SWG galv steel wire double strand saddle ties. Channels

... tied together with double strand of No. 18 SWG galv steel wire at each end of overlap.

- 8. **Batts and Blankets\*** - Optional - Any thickness mineral wool or glass fiber insulation bearing the UL Classification Marking for Surface Burning Characteristics, having a flame spread value of 25 or less and a smoke spread value of 50 or less. Insulation fitted in the concealed space, draped over the resilient channel/gypsum board ceiling membrane.
- 8A. **Loose Fill Material\*** - As an alternate to Item 8 - Any thickness of loose fill material bearing the UL Classification Marking for Surface Burning Characteristics, having a flame spread value of 25 or less and a smoke spread value of 50 or less. Insulation fitted in the concealed space, draped over the resilient channel/gypsum board ceiling membrane.
- 9. **Gypsum Board\*** - One layer of nom 5/8 in. thick by 48 in. wide boards, installed with long dimension parallel to trusses. Attached to the resilient channels using 1-1/8 in. long Type S bugle-head screws spaced 12 in. OC along butted end-joints and 12 in. OC in the field.

**NATIONAL GYPSUM CO** - Types FSW-C or FSW-G

- 10. **Finishing System** - (Not Shown) - Vinyl, dry or premixed joint compound, applied in two coats to joints and screw-heads; paper tape, 2 in wide, embedded in first layer of compound over all joints.

\*Bearing the UL Classification Mark

469858001

A not-for-profit organization dedicated to public safety and committed to quality service

BXUV/P540  
November 13, 2002