

MA - Multi-Use Secure Clip

Product Application

The MA multi-use secure clip is used in a variety of different applications, including head-of-wall, joist connections, rafter and truss connections, reinforcing header connections, and bridging.

The MA secure clip is designed to resist vertical and lateral loads. Pre-punched guide holes are provided in each leg to allow for efficient installation. Clips come packaged in durable buckets for easy handling on the jobsite.

Features and Benefits

- Variety of lengths available
- Loads based on #10 screws
- Pre-punched guide holes
- No labor used cutting scrap or angle

Material Composition

- Mill certified steel
- ASTM A653/A653M
- 54 mil
 - 57 ksi yield strength
 - 65 ksi tensile strength
 - G60 galvanized coating
- 68 mil
 - 57 ksi yield strength
 - 65 ksi tensile strength
 - G90 galvanized coating

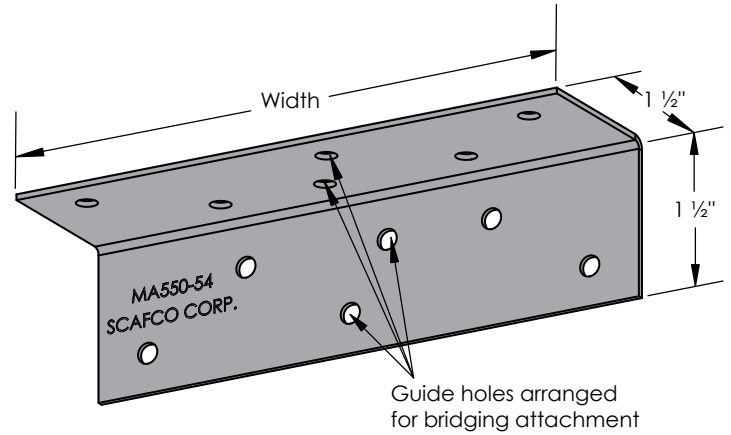

Quantity / Order Information

Part No.	Length	Qty / Bucket	Lbs / Bucket
MA350-54	3 1/2"	100	17
MA350-68	3 1/2"	100	21
MA550-54	5 1/2"	100	26
MA550-68	5 1/2"	100	32
MA750-54	7 1/2"	100	35
MA750-68	7 1/2"	100	44
MA950-54	9 1/2"	100	44
MA950-68	9 1/2"	100	55

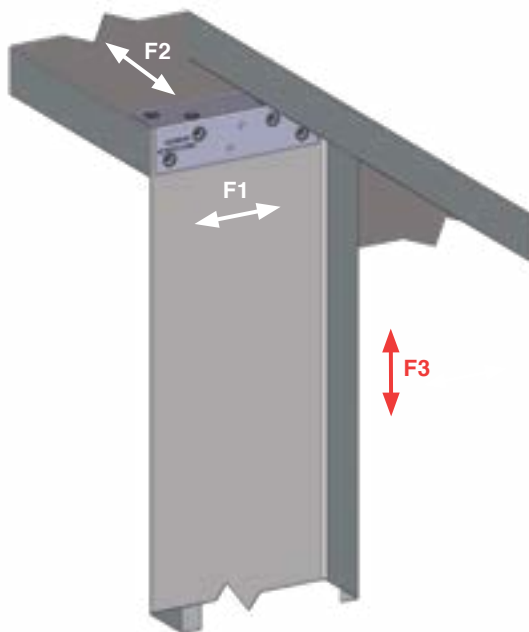

MA - Multi-Use Secure Clip Allowable Loads

Part No.	Stud Properties			F1 Allowable Loads (lbs)		F2 Allowable Loads (lbs)		F3 Allowable Loads (lbs)	
	Mil	Gauge	Fy (ksi)	2 #10 Screws	3 #10 Screws	2 #10 Screws	3 #10 Screws	2 #10 Screws	3 #10 Screws
MA350	33EQS	20	57	402	603	206	310	206	310
	33	20	33	353	530	168	251	168	251
	43EQS	18	57	635	952	280	420	280	420
	43	18	33	526	789	219	328	219	328
	54	16	50	1068	1602	396	594	396	594
	68	14	50	1510	2266	499	749	499	749
	97	12	50	2261	2420	712	965	712	965
Maximum Allowable Clip Capacity				Max F1 = 2420 lbs		Max F2 = 965 lbs		Max F3 = 965 lbs	

Part No.	Stud Properties			F1 Allowable Loads (lbs)			F2 Allowable Loads (lbs)			F3 Allowable Loads (lbs)		
	Mil	Gauge	Fy (ksi)	2 #10 Screws	4 #10 Screws	5 #10 Screws	2 #10 Screws	4 #10 Screws	5 #10 Screws	2 #10 Screws	4 #10 Screws	5 #10 Screws
MA550	33EQS	20	57	402	804	1005	206	413	516	206	413	516
	33	20	33	353	707	884	168	335	419	168	335	419
	43EQS	18	57	635	1269	1587	280	560	700	280	560	700
	43	18	33	526	1052	1315	219	437	547	219	437	547
	54	16	50	1068	2136	2671	396	792	855	396	792	855
	68	14	50	1510	2980	2980	499	855	855	499	855	855
	97	12	50	2261	2980	2980	712	855	855	712	855	855
Maximum Allowable Clip Capacity				Max F1 = 2980 lbs			Max F2 = 855 lbs			Max F3 = 855 lbs		

Part No.	Stud Properties			F1 Allowable Loads (lbs)			F2 Allowable Loads (lbs)			F3 Allowable Loads (lbs)		
	Mil	Gauge	Fy (ksi)	2 #10 Screws	4 #10 Screws	7 #10 Screws	2 #10 Screws	4 #10 Screws	7 #10 Screws	2 #10 Screws	4 #10 Screws	7 #10 Screws
MA750	33EQS	20	57	402	804	1407	206	413	722	206	413	722
	33	20	33	353	707	1237	168	335	597	168	335	597
	43EQS	18	57	635	1269	2221	280	560	980	280	560	980
	43	18	33	526	1052	1841	219	437	765	219	437	765
	54	16	50	1068	2136	3739	396	792	1387	396	792	1387
	68	14	50	1510	3021	5286	499	998	1740	499	998	1740
	97	12	50	2261	4521	6100	712	1424	1740	712	1424	1740
Maximum Allowable Clip Capacity				Max F1 = 6100 lbs			Max F2 = 1740 lbs			Max F3 = 1740 lbs		

Part No.	Stud Properties			F1 Allowable Loads (lbs)			F2 Allowable Loads (lbs)			F3 Allowable Loads (lbs)		
	Mil	Gauge	Fy (ksi)	2 #10 Screws	5 #10 Screws	9 #10 Screws	2 #10 Screws	5 #10 Screws	9 #10 Screws	2 #10 Screws	5 #10 Screws	9 #10 Screws
MA950	33EQS	20	57	402	1005	1809	206	516	929	206	516	929
	33	20	33	353	884	1590	168	419	754	168	419	754
	43EQS	18	57	635	1587	2856	280	700	1260	280	700	1260
	43	18	33	526	1315	2367	219	547	984	219	547	984
	54	16	50	1068	2671	4807	396	991	1740	396	991	1740
	68	14	50	1510	3776	6100	499	1248	1740	499	1248	1740
	97	12	50	2261	5652	6100	712	1740	1740	712	1740	1740
Maximum Allowable Clip Capacity				Max F1 = 6100 lbs			Max F2 = 1740 lbs			Max F3 = 1740 lbs		

Table Notes

- Allowable loads have not been increased for wind, seismic activity, or other factors.
- The allowable loads are based on the steel properties of the members being connected, per AISI S100.
- The nominal strength of the screw must be at least 3.75 times the allowable load.
- Screw shear capacities are based on allowable strength design (ASD) and include a safety factor of 3.0.
- Penetration of screws through joined materials should not be less than three exposed threads. Install and tighten screws in accordance with the screw manufacturer's recommendations.
- Allowable loads indicated on the table(s) are for force in single direction only. The designer shall use the combined forces check as required by AISI S100 if more than one force is applied to the connection.