

Product Application

The NT notched track is used for bracing and bridging of joists and wall studs. Notched Track is also used in hospitals and schools as mechanical backing that provides superior support for equipment and cabinetry.

Features and Benefits

- Available in widths of 4", 6", and 8"
- Available in 12", 16", and 24" stud spacing
- Pre-cut notches for flange attachment
- Eliminates field cutting
- Provides bracing and bridging support

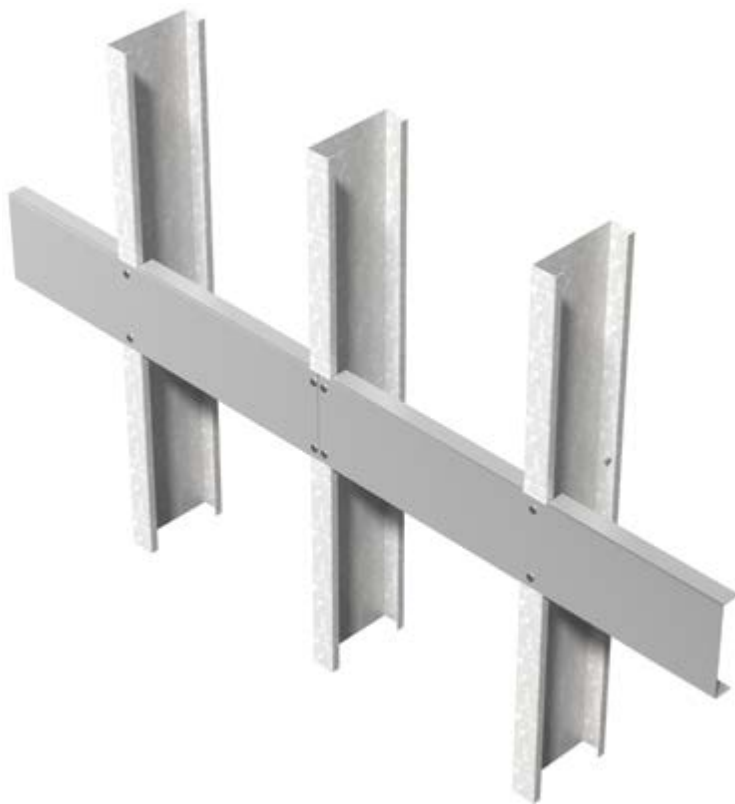
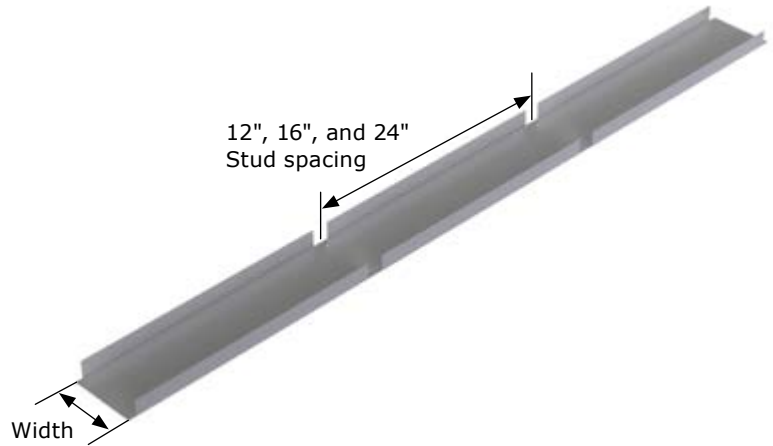

Material Composition

- Mill certified steel
- ASTM: A653/A653M
- 30 mil
 - 33 ksi yield strength
 - 45 ksi tensile strength
 - G40 galvanized coating
- 33 mil
 - 33 ksi yield strength
 - 45 ksi tensile strength
 - G60 galvanized coating
- 43 mil
 - 33 ksi yield strength
 - 45 ksi tensile strength
 - G60 galvanized coating
- 54 mil
 - 57 ksi yield strength
 - 65 ksi tensile strength
 - G60 galvanized coating
- 68 mil
 - 57 ksi yield strength
 - 65 ksi tensile strength
 - G90 galvanized coating

Nomenclature Example

Notched track system complies with standard SSMA nomenclature using the letters "NT" as the product identification. Use the following example when ordering notched track system.

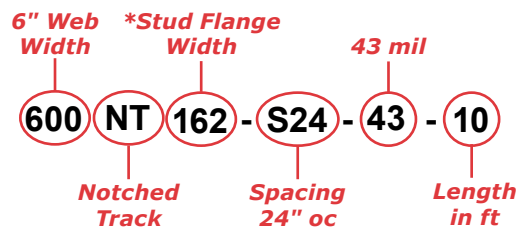

*Notch opening will be 1/8" larger than the stud flange width.