



XHBN.HW-D-0622 Joint Systems

[Page Bottom](#)

Design/System/Construction/Assembly Usage Disclaimer

- Authorities Having Jurisdiction should be consulted in all cases as to the particular requirements covering the installation and use of UL Listed or Classified products, equipment, system, devices, and materials.
 - Authorities Having Jurisdiction should be consulted before construction.
 - Fire resistance assemblies and products are developed by the design submitter and have been investigated by UL for compliance with applicable requirements. The published information cannot always address every construction nuance encountered in the field.
 - When field issues arise, it is recommended the first contact for assistance be the technical service staff provided by the product manufacturer noted for the design. Users of fire resistance assemblies are advised to consult the general Guide Information for each product category and each group of assemblies. The Guide Information includes specifics concerning alternate materials and alternate methods of construction.
 - Only products which bear UL's Mark are considered as Classified, Listed, or Recognized.
-

Joint Systems

[See General Information for Joint Systems](#)

System No. HW-D-0622

August 12, 2010

Assembly Ratings —1 and 2 HR

L Rating At Ambient — 2.1 CFM/LIN Ft

L Rating At 400 F — 1.33 CFM/LIN Ft

Nominal Joint Width —1/4, 1/2 or 1 in. (See Item 3)

Class II and III Movement Capabilities — 100% Compression or Extension

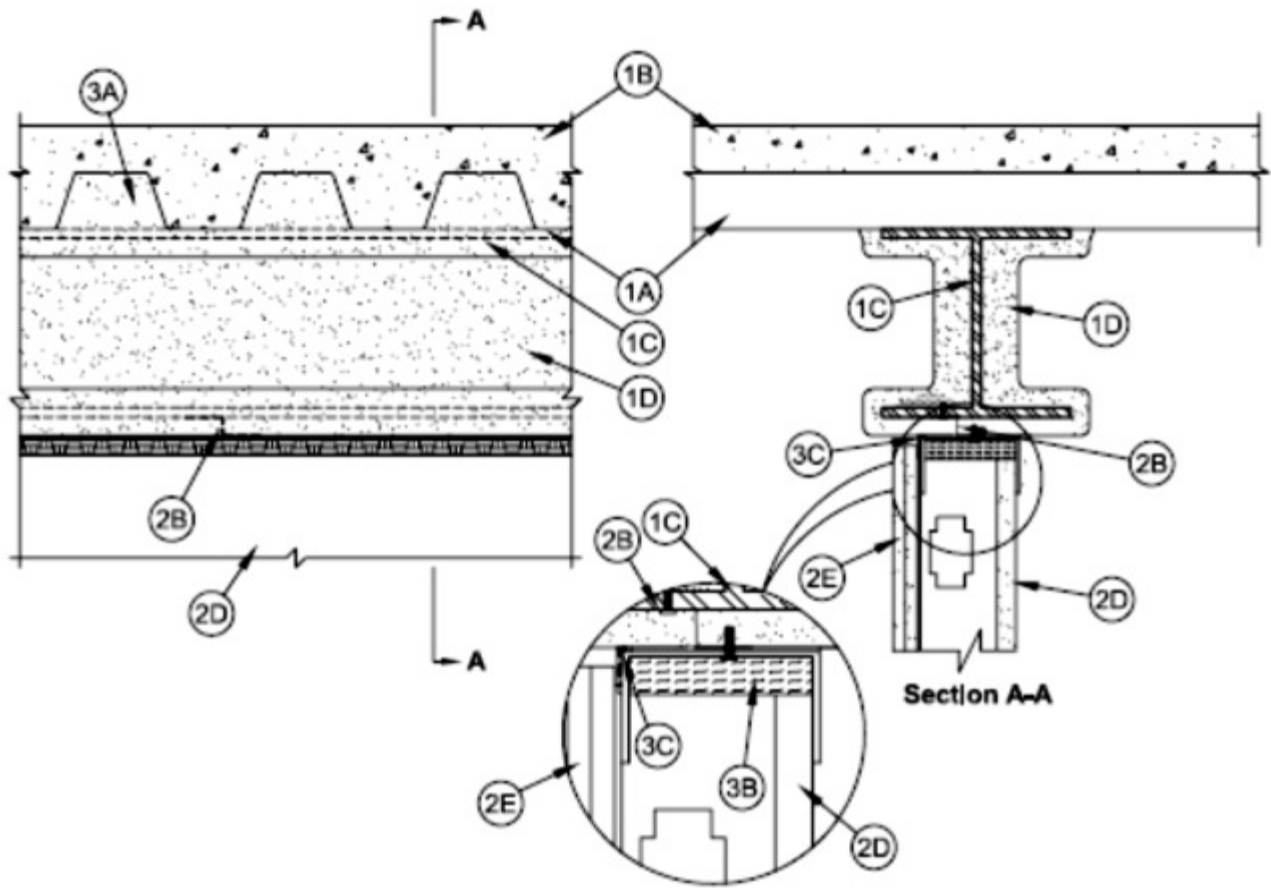

1. **Floor Assembly** — The fire-rated fluted steel deck/concrete floor assembly shall be constructed of the materials and in the manner described in the individual D700 or D900 Series Floor-Ceiling Design in the UL Fire Resistance Directory and shall include the following construction features:

- A. **Steel Floor And Form Units*** — Max 3 in. (76 mm) deep galv steel fluted floor units.
- B. **Concrete** — Min 2-1/2 in. (64 mm) thick reinforced concrete, as measured from the top plane of the floor units.
- C. **Structural Steel Support** — Steel beam, as specified in the individual D700 or D900 Series Floor-Ceiling Design, used to support steel floor units. Steel Beam centered over and parallel with wall assembly.
- D. **Spray-Applied Fire Resistive Material*** — After installation of the steel attachment clips (Item 2B), steel floor units, and ceiling runner (Item 3), all surfaces of the steel floor units and structural steel support to be sprayed with the thickness of material specified in the individual D700 or D900 Series Floor-Ceiling Design. The flutes of the steel floor units are to be filled with material across the entire top flange of the steel beam. The areas between the bottom flange of the structural support and top of the ceiling runner are to be filled entirely with material. Additional material shall be applied to the web of the steel beam on each side of the wall. The thickness of material applied to each side of the steel beam web shall be 2 in. (51 mm).

ISOLATEK INTERNATIONAL — Type 300

W R GRACE & CO - CONN — — Type MK-6/HY

1A. **Roof Assembly** — (Not Shown) - As an alternate to the floor assembly, a fire rated fluted steel deck roof assembly may be used. The roof shall be constructed of the materials and in the manner described in the individual P700 or P900-Series Roof-Ceiling designs in the UL Fire Resistance Directory. The hourly rating of the roof assembly shall be equal to or greater than the hourly rating of the wall assembly. The roof assembly shall include the following construction features:

- A. **Steel Roof Deck** — Max 3 in. (76 mm) deep galv steel fluted roof deck.
- B. **Roof Insulation** — Roof insulation to consist of min 2-1/4 in. (57 mm) thick poured insulating concrete, as measured from the top plane of the roof deck.
- C. **Structural Steel Support** — Steel Beam, as specified in the individual P700 or P900 Series Floor-Ceiling Design, used to support steel floor units. Steel Beam centered over and parallel with wall

assembly.

D. Spray-Applied Fire Resistive Material* — After installation of the steel attachment clips (Item 2B), steel floor units, and ceiling runner (Item 3), all surfaces of the steel floor units and structural steel support to be sprayed with the thickness of material specified in the individual P700 or P900 Series Floor-Ceiling Design. The flutes of the steel floor units are to be filled with material across the entire top flange of the steel beam. The areas between the bottom flange of the structural support and top of the ceiling runner are to be filled entirely with material. Additional material shall be applied to the web of the steel beam on each side of the wall. The thickness of material applied to each side of the steel beam web shall be 2 in. (51 mm).

ISOLATEK INTERNATIONAL — Type 300

W R GRACE & CO - CONN — — Type MK-6/HY

2. **Wall Assembly** — The 1 or 2 hr fire rated gypsum board/stud wall assembly shall be constructed of the materials and in the manner described in the individual U400 or V400 Series Wall and Partition Design in the UL Fire Resistance Directory and shall include the following construction features:

A. Steel Floor and Ceiling Runners — Floor runner U-shaped, sized to accommodate steel studs (Item 2C), fabricated from 24 ga galv steel. Ceiling runner positioned with slotted leg toward finished side of wall. Runners attached to floor with steel fasteners located not greater than 2 in. from ends and not greater than 24 in OC. The ceiling runners are provided with a fill, void or cavity material and are described in Item 3.

B. Steel Attachment Clips — Z-shaped clips formed from 1 in. (25 mm) wide strips of min 20 ga galv steel. Clips sized to extend through the thickness of the spray-applied fire resistive material on the bottom flange of the steel beam with 1-1/2 in. (38 mm) long upper and lower legs. Legs of clips fastened to bottom of beam (prior to application of spray-applied fire-resistive materials) and top of ceiling runner with steel fasteners or welds. Clips spaced max 16 in. (406 mm) OC.

C. Studs — "C-T", "I", or "C-H" shaped steel studs to be min 2 1/2 in. (64 mm) wide and formed of min 24 ga galv steel. Studs cut 1/2 to 1-1/4 in (13 to 32 mm) less in length than assembly height for 1/2 in. or 1 in. joint respectively with bottom nesting in and secured to floor runner. Steel studs secured to slotted leg of ceiling runner on finished side with No. 8 by 1/2 (13 mm) long wafer head steel screws at mid-height of exposed slot. Studs spaced max 24 in. (610 mm) OC

D. Gypsum Board* — 1 in. (25 mm) thick by max 24 in. (610 mm) wide gypsum board liner panels. Panels cut 1 in. less in length than floor to ceiling height. Vertical edges inserted into "T" shaped section of "C-T" studs, into holding tabs of "I" studs or into "H"-shaped section of "C-H" studs.

E. Gypsum Board* — Gypsum board 1/2 or 5/8 in. (13 or 16 mm) thick, applied on finished side of wall as specified in the individual Wall and Partition Design. The boards cut a max 1/2" in. less in length than the floor to ceiling height. The screws attaching the gypsum board layer(s) to the "C-T", "I", or "C-H" studs shall be located 4 to 5 in. (102 to 127 mm) down from deck at time of installation.

3. **Joint System** — Max separation between spray applied material and top of gypsum board (at time of installation) is 1/4, 1/2 or 1 in. (6,13 or 25 mm). The joint system is designed to accommodate a max 100 percent compression or extension from its installed width. For nom 1/4 in. (6 mm) joint see item 3C1, for nom 1/2 in. (13 mm) joint see Item 3C2 for nom 1 in. (25 mm) joint see Item 3C3.

A. Forming Material* — Min 4 pcf (64 kg/m³) mineral wool insulation cut to the shape of the fluted steel floor units, approx 33% larger than the area of the flutes. Pieces compressed and inserted into the flutes above the top ceiling runner flush with the finished wall surface.

B. Forming Material* — Min 2 in. thick min 4 pcf (64 kg/m³) mineral wool batt insulation cut to the width of the ceiling runner and compressed 50 percent in thickness, installed into ceiling runner between leg of track and gypsum liner board.

C1. Fill, Void or Cavity Material* — Nom 20 ga J-shaped track having a 3" in. and a 2 in. leg (83 and 51 mm) legs with a nom 1/2 in. (13 mm) wide intumescent strip affixed to the top of the leg overlapping on to top surface a min of 1/4 in. (6 mm) facing the finished side of wall. Track to be secured to bottom side of floor assembly with steel masonry or powder actuated fasteners spaced at a max of 24 in. (610 mm) OC.

CALIFORNIA EXPANDED METAL PRODUCTS CO — FAS SHAFT Track 500

C2. Fill, Void or Cavity Material* — (For Nom 1/2 in. Joint) Nom 20 ga U-shaped track having 3 in (76 mm) legs with a nom 1-1/4 in. (32 mm) wide intumescent strip affixed to the top of the leg overlapping on to top surface a min of 1/4 in. (6 mm) facing the finished side of wall. Gypsum board to overlap a min of 1/2 in. (13 mm) over the intumescent strip. Track to be secured to bottom side of floor assembly with min 2 in. (51 mm) steel masonry or powder actuated fasteners spaced at a max of 24 in. (610 mm) OC.

C3. **Fill, Void or Cavity Material*** — (for Nom 1 in. Joint) Nom 20 ga U-shaped track having 3-1/4 in (83 mm) legs with a nom 2-1/2 in. (64 mm) wide intumescent strip affixed to the top of the leg overlapping on to top surface a min of 1/4 in. (6 mm) facing the finished side of wall. Gypsum board to overlap a min of 1 in. (25 mm) over the intumescent strip. Track to be secured to bottom side of floor assembly with min 2 in. (51 mm) steel fasteners spaced at a max of 24 in. (610 mm) OC.

*Bearing the UL Classification Mark

Last Updated on 2010-08-12

[Questions?](#)

[Print this page](#)

[Notice of Disclaimer](#)

[Page Top](#)

[Copyright © 2010 Underwriters Laboratories Inc.®](#)

The appearance of a company's name or product in this database does not in itself assure that products so identified have been manufactured under UL's Follow-Up Service. Only those products bearing the UL Mark should be considered to be Listed and covered under UL's Follow-Up Service. Always look for the Mark on the product.

UL permits the reproduction of the material contained in the Online Certification Directory subject to the following conditions: 1. The Guide Information, Designs and/or Listings (files) must be presented in their entirety and in a non-misleading manner, without any manipulation of the data (or drawings). 2. The statement "Reprinted from the Online Certifications Directory with permission from Underwriters Laboratories Inc." must appear adjacent to the extracted material. In addition, the reprinted material must include a copyright notice in the following format: "Copyright © 2010 Underwriters Laboratories Inc.®"

An independent organization working for a safer world with integrity, precision and knowledge.

