

SERENITY-RC-PLUS



#1 CHOICE FOR
Sound Assemblies

Steel-Con

**Steel
Construction
Systems™**



**TESTED
BY**

**Riverbank Acoustical
LABORATORIES™**

An  ALION Technical Center

SERENITY-RC-PLUS

Serenity-RC-Plus is a premium product and the best cost effective solution for reducing the transmission of airborne sound through walls and ceilings. By separating the drywall from the stud flange, the channel minimizes the direct path by which sound travels through the framing, as detailed on page 3.

Steel-Con's Serenity-RC-Plus was professionally sound tested at Riverbank Acoustical Laboratories, one of the leading and longest-standing acoustical testing facilities in the United States. Acoustical testing for the STC performance of Serenity-RC-Plus proved the product's ability to provide high-end sound performance for both steel and wood framed assemblies, well above other high-end RC products available.

» Premium Product

- Exceptional control of sound transmission through ceilings and partition wall assemblies
- Lab Certified STC Rating up to 61

Material Composition

- D-20 material
 - 57 ksi min. yield strength
 - 65 ksi min. tensile strength
 - G40 galvanized coating
- ASTM A653/A653M

Serenity Profile

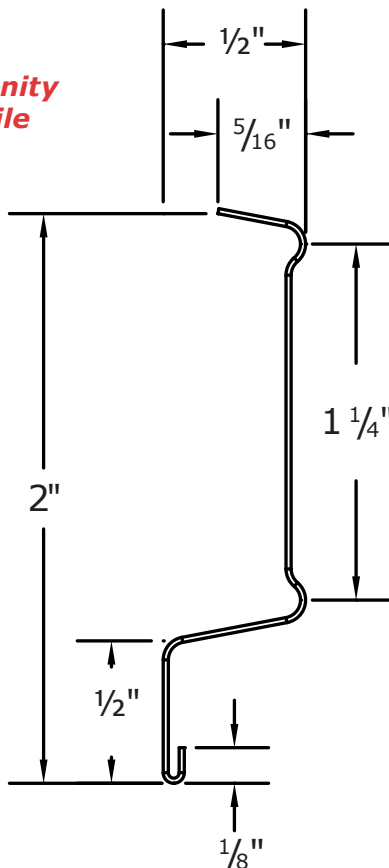

TESTING

Riverbank Acoustical Laboratories

Sound assemblies are constructed, thoroughly inspected and then certified by Riverbank Acoustical Laboratories. NVLAP accredited for ASTM E90-09 & E413-10, ISO Certified.

Riverbank Acoustical Laboratories is accredited by the US department of commerce, National Voluntary Laboratory Accreditation Program (NVLAP Lab Code 100227-0) to ISO 17025:2005 laboratory quality management and specific acoustical test standards.



SSA Acoustics

SSA Acoustics, a leader in engineering acoustics and multi-family residential design for 17 + years, has conducted extensive testing and research on Steel-Con's Serenity Resilient Channel.

SSA's team of acoustical consultants and lab technicians tested Serenity-RC-Plus for isolation efficiency, and in-field performance. When comparing the results gathered to those of other products within the industry, the team found that Serenity-RC-Plus is the superior product for reducing airborne transmission in walls and ceilings, for both wood and steel assemblies.

Serenity-RC-Plus consistently measured better than its competitors in isolation and efficiency tests, both critical to obtaining elevated STC (Sound Transmission Class) performance. SSA's group of highly qualified consultants continue to research, develop and test the product to ensure it meets all required sound specifications.

The all-around performance of Serenity-RC-Plus impressed Bill Stewart the managing partner of SSA Acoustics:

» ***"The superior performance of Serenity-RC-Plus in lab and field testing is un-matched. Recommended as our basis of design in all resilient channel applications"***

TESTED by
SSA acoustics

Bill Stewart www.ssaacoustics.com (206) 839-0819

Profile Features

Serenity-RC-Plus has been engineered, with help from the acoustical community, to include the following features that reduce sound transmission through the assembly.

» Slot and Hole Pattern

- 1/4" x 5/16" Slots
- 3/16" (#8 Screw) Holes
- Slots and holes are aligned to increase the path that sound must travel through the assembly
- 2" Slot spacing along the channel allows for wall and ceiling framing at almost any spacing conditions including the typical 12" o.c., 16" o.c., and 24" o.c.

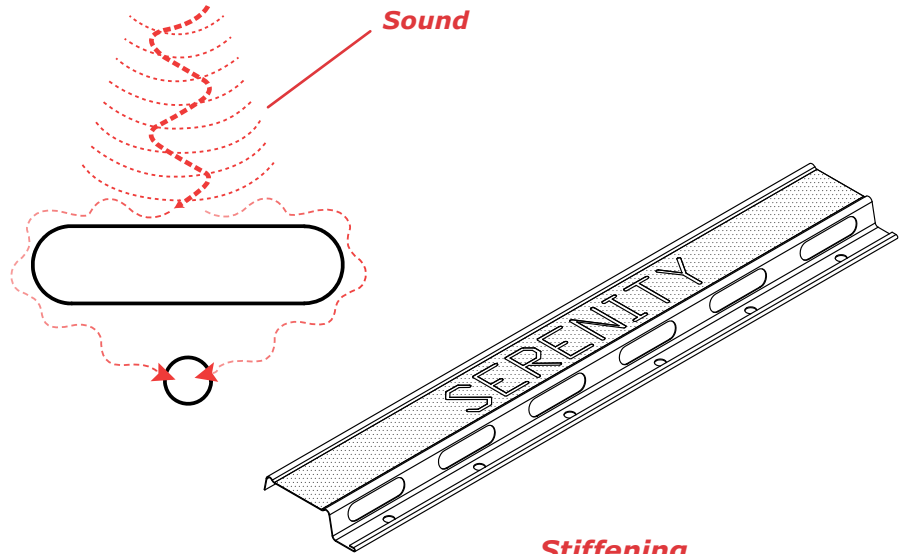

» Stiffening Ribs

- 1/16" Raise stiffening ribs
- Creates separation and air space between sheathing and framing stud
- Only 2 points of contact between sheathing and framing stud, decreases area for sound transmission

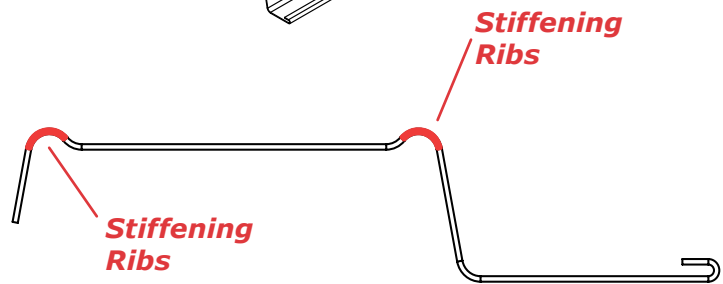

» Serenity's Knurling

- Stiffens attachment flange to create gap between sheathing
- Aids in positive screw attachment through thin acoustical steel profile

Serenity knurling is product identification on the jobsite



METAL FRAMING

Features and Benefits

- Cost effective sound management on metal framing
- Decoupling across all frequencies
- Easily attached through pre-punched holes
- Tested with single and double layer drywall
- Available in 12' lengths



52 STC

- 3 5/8" Metal stud 24" o.c.
- R-13 Insulation
- Serenity-RC-Plus (one side)
- 5/8" Type X GWB (single layer both sides)



58 STC

- 3 5/8" Metal stud 24" o.c.
- R-13 Insulation
- Serenity-RC-Plus (one side)
- 5/8" Type X GWB (single layer one side, double layer opposite side)



61 STC

- 3 5/8" Metal stud 24" o.c.
- R-13 Insulation
- Serenity-RC-Plus (one side)
- 5/8" Type X GWB (double layer both sides)

Serenity-RC-Plus with Cold-Formed Metal Framing

Serenity-RC-Plus is formed from D20 galvanized steel, and when used in connection with sound attenuation blankets, it increases the effectiveness of the sound resistant assembly. Serenity-RC-Plus is installed horizontally at 24" o.c. and is easily attached with framing screws through its pre-punched holes.

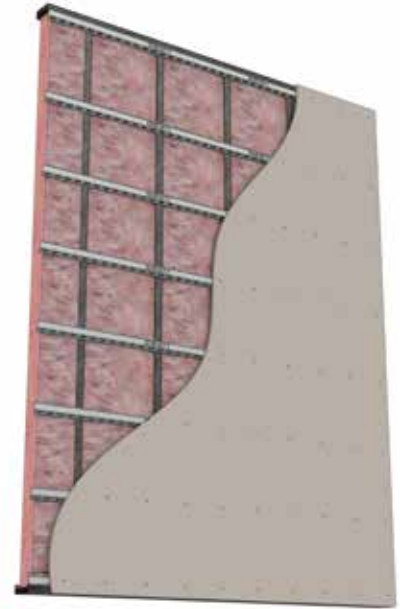

Serenity-RC-Plus Assembly

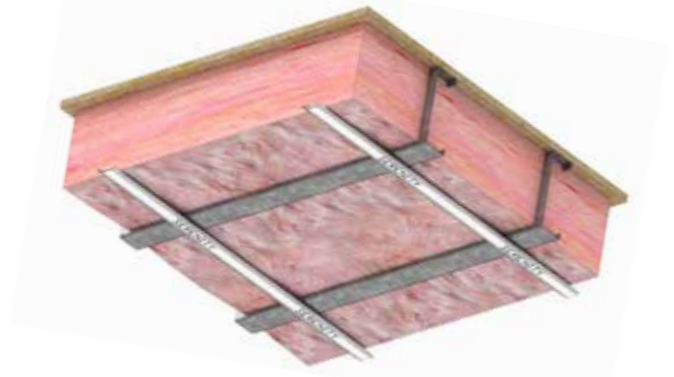

Serenity-RC-Plus Ceiling Assembly



WOOD FRAMING

Features and Benefits

- Cost effective sound management on wood framing
- Decoupling across all frequencies
- Tested on 2x4 and 2x6 wood studs
- Tested with single and double layer drywall
- Available in 12' lengths

Serenity-RC-Plus with Wood Framing

Serenity-RC-Plus effectively isolates drywall from wood studwork and substantially weakens sound waves traveling through them. Attaching Serenity-RC-Plus in wood applications is nearly effortless and will provide superior STC ratings beyond other resilient channel products on the market.

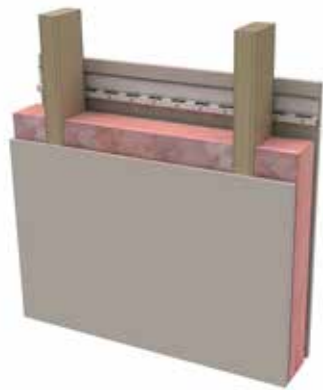

46 STC (2x4 studs)
48 STC (2x6 studs)

- Framing at 24" o.c.
- R-13, R-19 Insulation
- Serenity-RC-Plus (one side)
- 5/8" Type X GWB (single layer both sides)

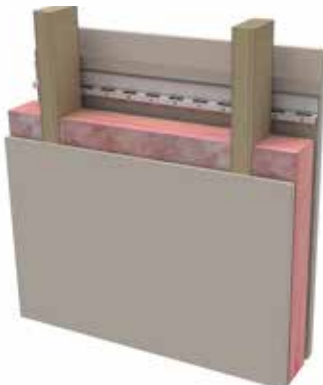

53 STC (2x4 studs)
53 STC (2x6 studs)

- R-13, R-19 Insulation
- Serenity-RC-Plus (one side)
- 5/8" Type X GWB (single layer one side, double layer opposite side)



58 STC (2x4 studs)
58 STC (2x6 studs)

- R-13, R-19 Insulation
- Serenity-RC-Plus (one side)
- 5/8" Type X GWB (double layer both sides)

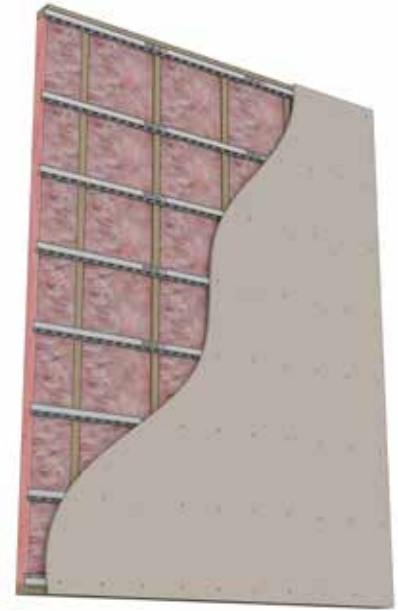

Serenity-RC-Plus Assembly



Serenity-RC-Plus Ceiling Assembly



Installation Instructions

Serenity-RC-Plus Channel must be installed per specifications of the USG Drywall's Handbook, ASTM C754 "Installation of Steel Framing Members to Receive Screw Attached Gypsum Panel Products", and Steel-Con's Manufacturer Instructions.

A full list of Steel-Con's installation instructions for steel and wood assemblies can be found at www.SteelConSystems.com, or by contacting Technical@SteelConSys.com.

The following details illustrate important installation considerations:

» General Requirements:

- For single layer drywall assemblies utilize 1" long framing screws for attachment to resilient channel flange. For attachment through two layers use 1 5/8" long fasteners.
- DO NOT fasten through resilient channel flange and into wall/ceiling studs. Longer fasteners will result in short circuit and reduced performance of the resilient channel. See detail C.

» Wall Assemblies:

- Install Serenity-RC-Plus horizontally and space 24" o.c to match the laboratory test data.
- Install Serenity-RC-Plus channel to wood or steel studs 2" from floor and within 6" from top of wall, with steel/wood fasteners providing sufficient anchorage. The attachment flange shall be installed below face of channel for all rows except bottom row which will be inverted.
- Allow 1/4" gap from resilient ceilings, and 1/8" minimum gap for acoustical caulk around all other edges. Do not rest gypsum board on floor, intersecting walls, or ceilings.
- Cabinets or other wall hung items mounted on resilient channel walls cannot be attached through to the studs. Utilize toggle bolts if gypsum board is adequate for strength, if not utilize different acoustical assembly.

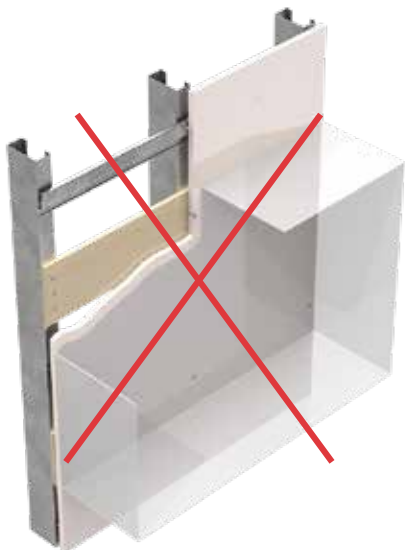

Backing creates an Acoustic Short Circuit

WALL ASSEMBLIES

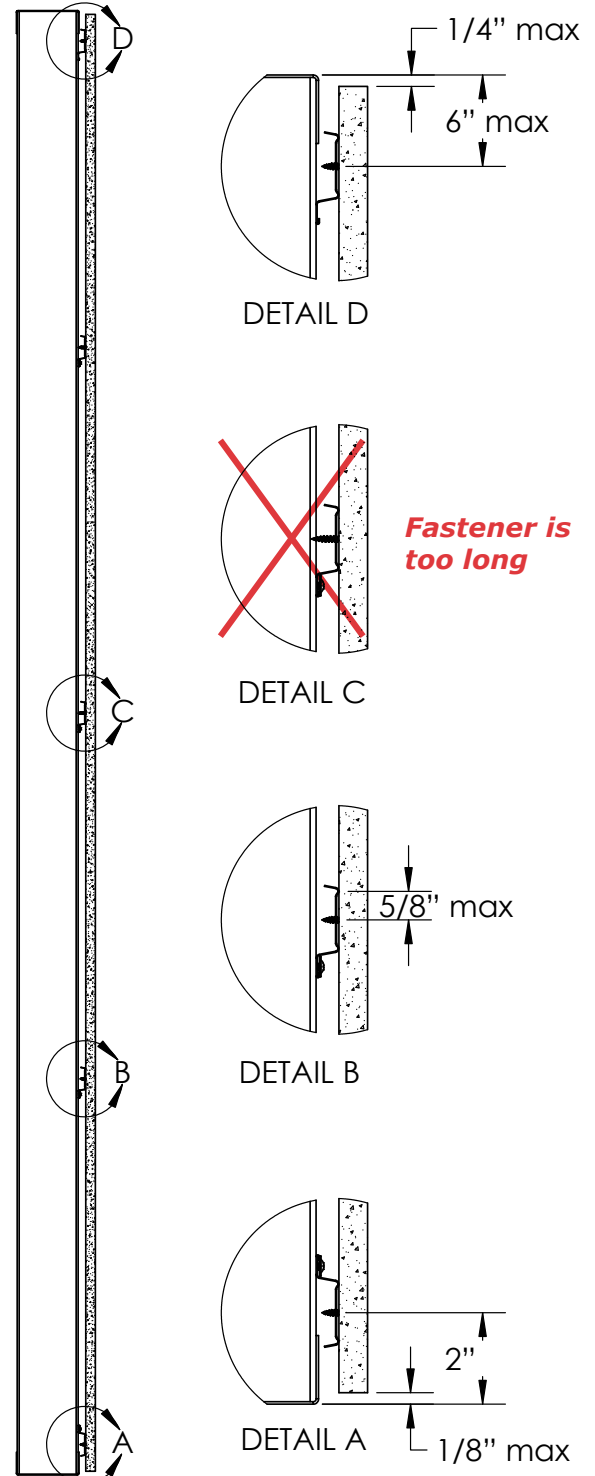

CEILING ASSEMBLIES

Serenity-RC-Plus with Ceiling Assemblies

Serenity-RC-Plus is ideal for reducing sound passing through ceiling assemblies. Its quick and easy installation immediately diminishes both airborne noise and impact sound to achieve the best STC ratings in the industry.

» Ceiling Assemblies:

- Attach Serenity-RC-Plus perpendicular to the ceiling joists 24" o.c. for joists 16" o.c.; 16" o.c. for joists 24" o.c. For multiple layers of Gypsum Board decrease spacing of resilient channel. Spacing should be decreased in conjunction with the weight of boards/materials added, to provide sufficient anchorage and load distribution.

- Allow 1/8" gap for acoustical calk around all edges. Do not rest edge of boards on adjacent walls or ceilings.

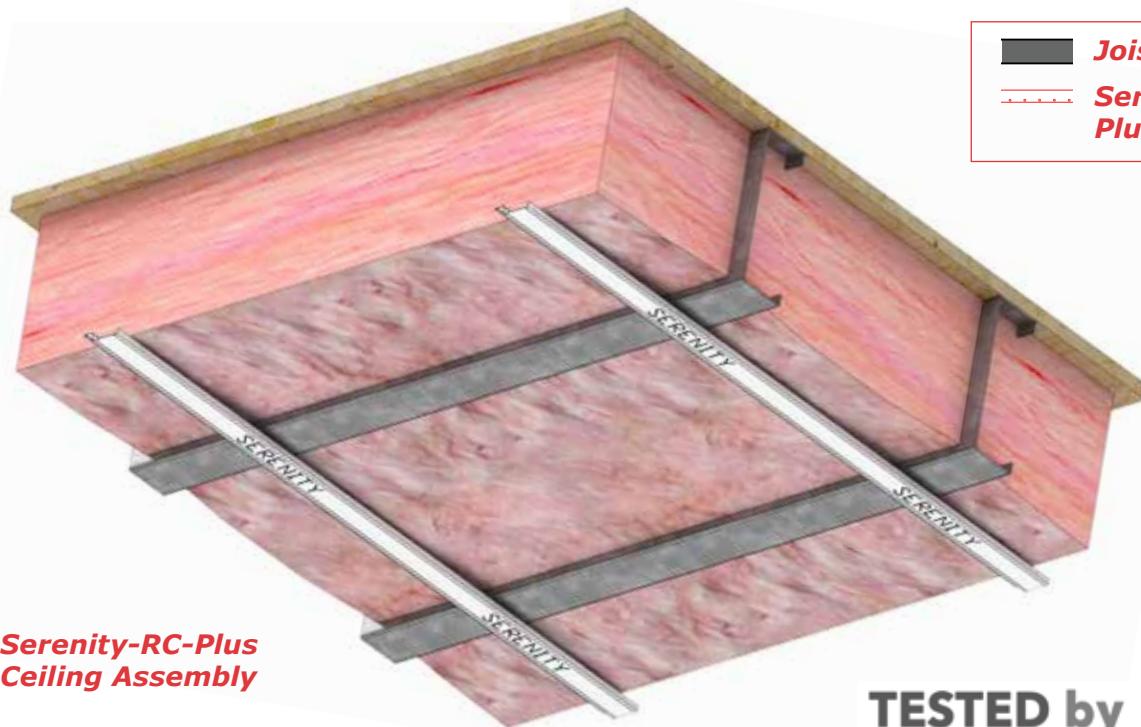
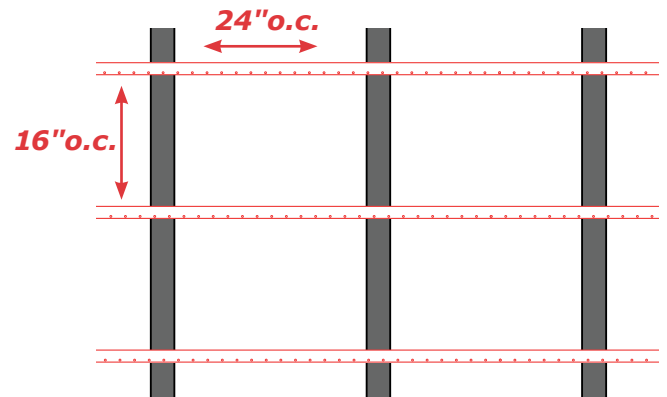

Joist
Serenity-RC-Plus Channel

Serenity-RC-Plus Ceiling Assembly

TESTED by
SSA acoustics

Steel-ConTM

**Steel Construction
Systems**

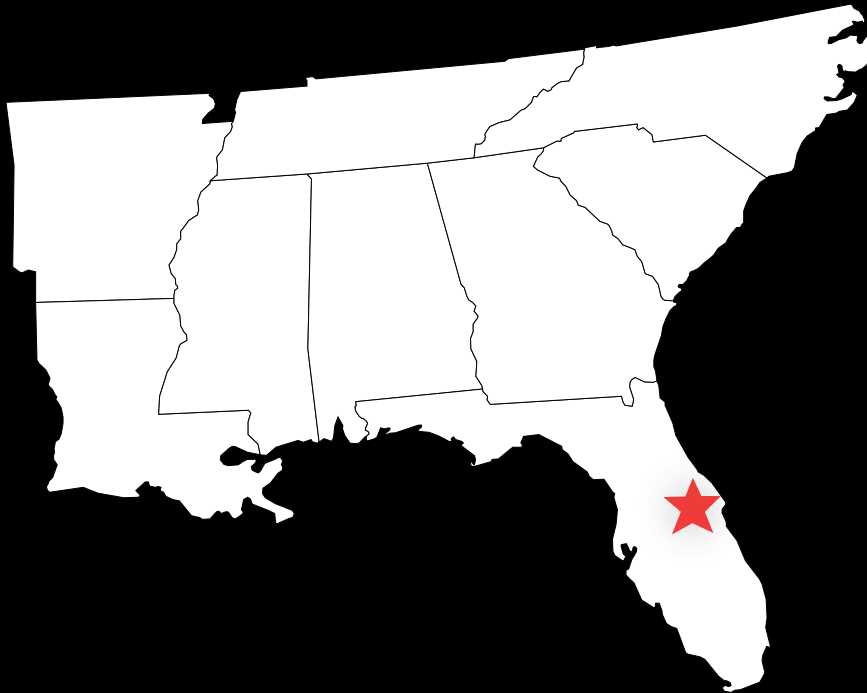

Servicing the Southeastern United States

Orlando Office
11250 Astronaut Blvd
Orlando, FL 32837
Ph: 407-438-1664

www.SteelConSystems.com